

TORQUE RATING: 11,000 FT-LBS
 COMPRESSION RATING: 110 KIP
 TENSION RATING: 100 KIP

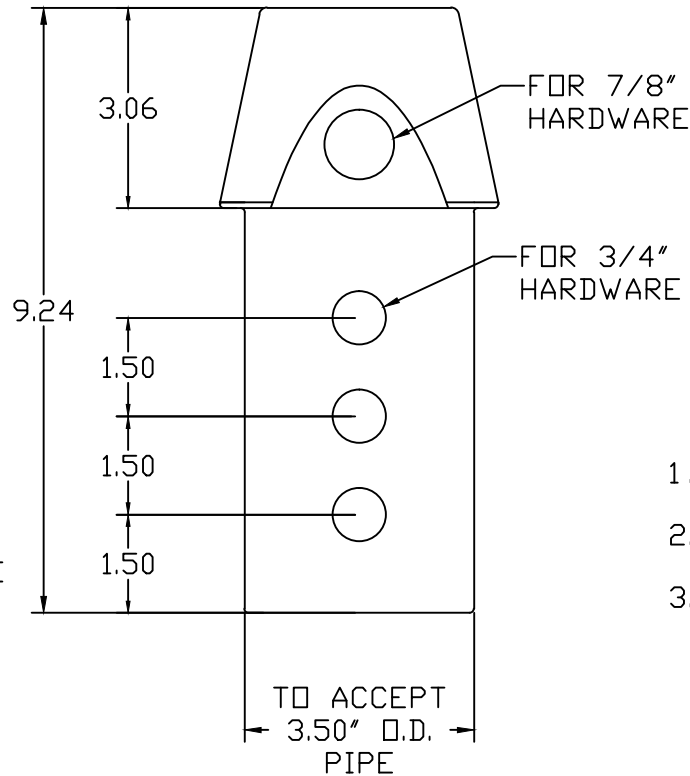
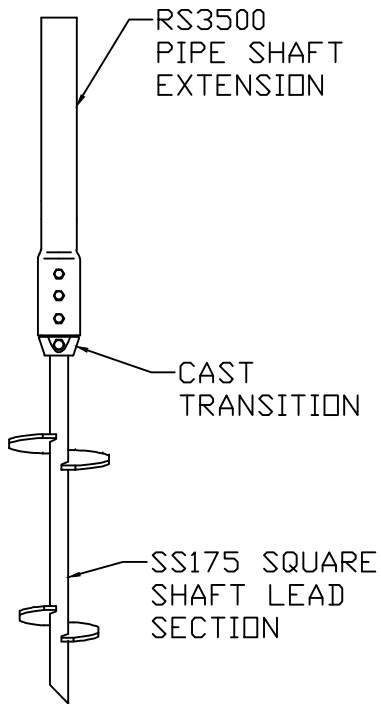
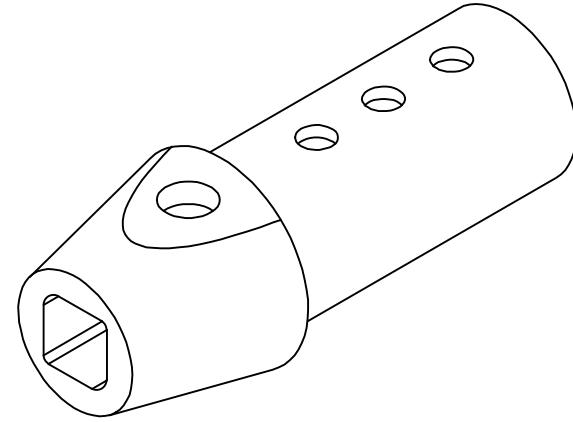
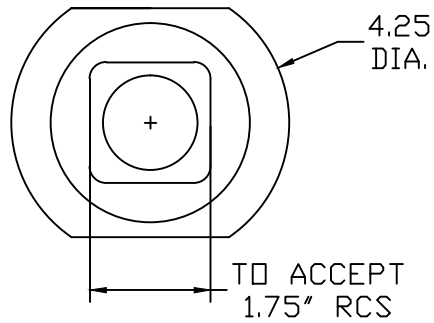

-NOTES-

1. MATERIAL: CAST DUCTILE IRON PER ASTM A536 65-45-12.
2. FINISH: HOT DIP GALVANIZED PER ASTM A153.
3. HARDWARE: 7/8" HEX HEAD BOLT PER ASTM A193 GRADE B7.

TYPICAL PIER ASSEMBLY

CATALOG NUMBER:
 C1500895

CHANCE		HUBBELL POWER SYSTEMS	
<small>CONFIDENTIAL: THIS DRAWING AND ITS CONTENTS ARE CONFIDENTIAL AND THE EXCLUSIVE PROPERTY OF HUBBELL POWER SYSTEMS. NO PUBLICATION, DISTRIBUTION OR COPIES MAY BE MADE WITHOUT THE WRITTEN CONSENT OF HUBBELL POWER SYSTEMS. HUBBELL POWER SYSTEMS UNPUBLISHED ALL RIGHTS RESERVED UNDER THE COPYRIGHT LAWS.</small>		TITLE TRANSITION, CAST 1.75" RCS TO 3.50" PIPE	
SIZE B	DWG NO. SA1500895	REV --	DATE 5/16/11
DO NOT SCALE THIS DRAWING	DRN BY TLW	SHEET 1 OF 1	DATE 5/16/11

INDICATES A
 CF CRITICAL FEATURE