

COMPRESSION/TENSION NEW CONSTRUCTION CAPS FOR SQUARE SHAFTS

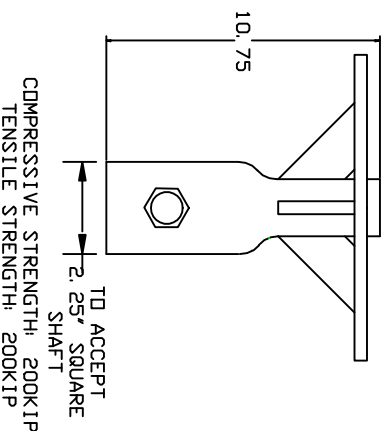
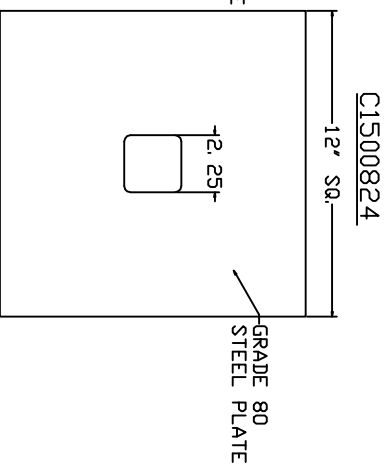
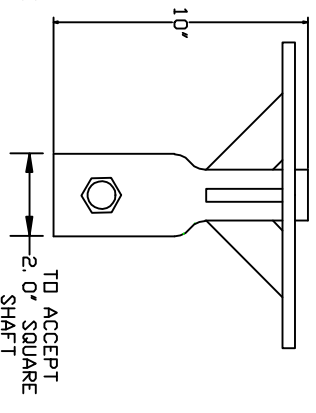
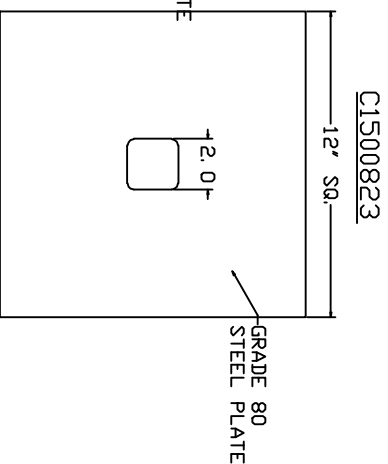
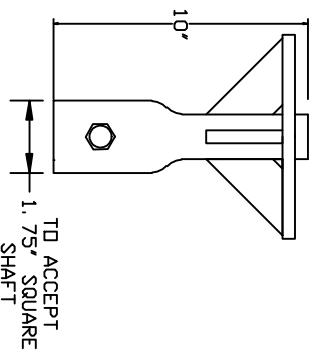
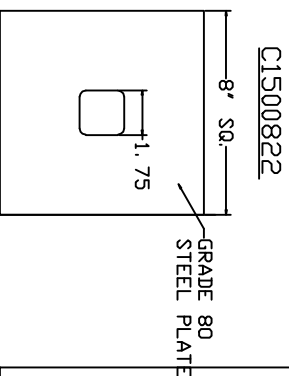
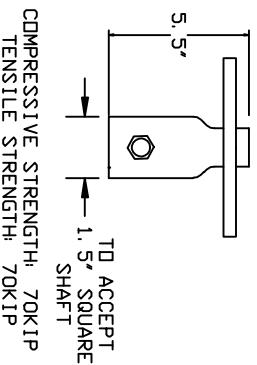
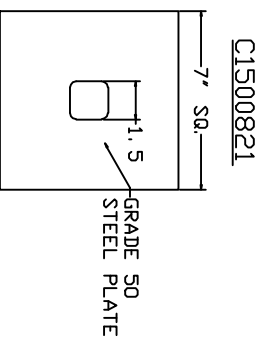

=NOTES=

1. FINISH: STANDARD CATALOG NUMBER IS MILL FINISH STEEL.
TO ORDER GALVANIZED FINISH ADD 'G' TO STANDARD CATALOG NUMBER.
2. MATERIAL SPECIFICATIONS:
 - PLATE: HOT ROLLED STEEL PER ASTM A572 GRD. 50.
 - OR HOT ROLLED STEEL PER ASTM A656 GRD. 80.
 - SOCKET: ROUND CORNER SQUARE STEEL BAR PER TT-76
 - BOLT: 3/4" HEX HEAD BOLTS PER ASTM A325 TYPE 1.
 - 7/8", 1-1/8", AND 1-1/4" HEX HEAD BOLTS PER ASTM A193.

| | | | |
|----------------------------------------------------------------------------------------------------------------------------------------------------------------------------------------------------------------------------------------------------------|---------------------------------------------|------------------------------|--------------|
| CHANCE TOLERANCE CHART | | HUBBELL POWER SYSTEMS | |
| CONFIDENTIAL: THIS DRAWING AND ITS CONTENTS ARE CONFIDENTIAL AND THE POWER SYSTEMS NO PUBLICATION, DISTRIBUTION OR COPIES MAY BE MADE WITHOUT THE WRITTEN PERMISSION OF HUBBELL POWER SYSTEMS. UNPUBLISHED ALL RIGHTS RESERVED UNDER THE COPYRIGHT LAWS. | | | |
| TITLE | COMPRESSION/TENSION CONSTRUCTION CAP | | |
| SIZE | DWG NO. | CUT / PART / ASSY NO. | REV |
| SB | SA1600821 | SEE DRAWING | - |
| DO NOT SCALE THIS DRAWING | | DEN BY ADM | DATE 7/16/10 |
| | | SHEET | 1 OF 1 |