

**-NOTES-**

1. FINISH: HOT DIP GALVANIZE PER ASTM-A153 (LATEST REVISION), BASEPLATE TO BE PERPENDICULAR TO SHAFT AXIS (±1°) AND HOLE CENTERLINE CONCENTRIC (±.188) TO SHAFT AXIS.
2. STENCIL MIN. 1/2 IN. LETTERS MANUFACTURER'S NUMBER AFTER GALVANIZING.
3. PILOT POINT AND SHAFT AXES TO BE CONCENTRIC (±.125 FIM) AND IN LINE (±2°).
4. FLAME CUT TWO SLOTS IN SHAFT PERPENDICULAR TO THE BASEPLATE. PREHEAT, TUMBLEBLAST, HANDGRIND, AND CLEAN BASEPLATE, HELIX, AND PILOT POINT ON ALL WELDED AREAS.
5. FLAMECUT IRREGULARITIES PERMISSIBLE: (1) VALLEYS NOT TO EXCEED 3/32 IN. BELOW NOMINAL SURFACE LEVEL, (2) PEAKS OR POSITIVE IRREGULARITIES NOT TO EXCEED 1/32 IN. ABOVE NOMINAL SURFACE LEVEL OR INTERSECTIONS OF NOMINAL SURFACES.
6. MANUFACTURER TO HAVE IN EFFECT INDUSTRY RECOGNIZED WRITTEN QUALITY CONTROL FOR ALL MATERIALS AND MANUFACTURING PROCESSES. ALL MATERIAL IS TO BE NEW, UNUSED AND MILL TRACEABLE MEETING THE FOLLOWING SPECIFICATIONS:
7. BASEPLATE: ASTM A36-(LATEST REVISION) STRUCTURAL STEEL (CONFORM TO AASHTO TECH. BUL. #270).
8. SHAFT: ASTM A522-(LATEST REVISION) GRADE 2, STEEL PIPE PILES. ALTERNATE MATERIAL: ASTM A53-(LATEST REVISION) TYPE E OR S. GRADE B, STEEL PIPE OR ASTM A500-(LATEST REVISION) GRADE B, STRUCTURAL STEEL TUBING.
9. HELIX: ASTM A635-(LATEST REVISION) 3/8" THICK HOT ROLLED STEEL PLATE OR COIL.
10. PILOT POINT: ASTM A575-(LATEST REVISION) 1-1/4" DIAMETER HOT ROLLED STEEL BAR.
11. BOLTS: CARRIAGE BOLTS, 1-8UNC-2A ANSI B-18.5, SAE J429 GRADE 5.

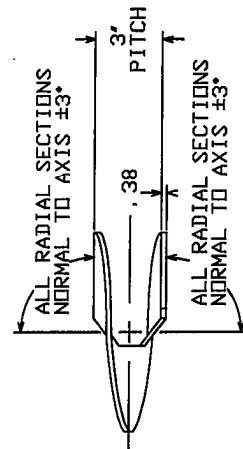
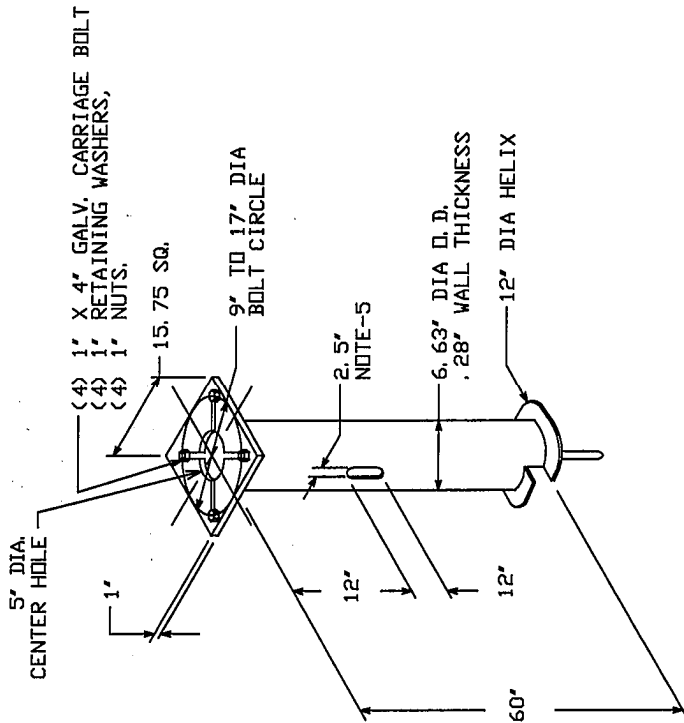

HELIX MUST BE FORMED BY MATCHING METAL DIE  
(SIDE VIEW OF TRUE HELICAL FORM)

*LIGHTING FOUNDATION  
CAT. NO. 1112-0296*

CHANCE <small>CONFIDENTIAL: THIS DRAWING AND ITS CONTENTS ARE CONFIDENTIAL AND THE EXCLUSIVE PROPERTY OF HUBBELL POWER SYSTEMS. NO REPRODUCTION, DISTRIBUTION, OR DISSEMINATION, IN ANY MANNER, IS PERMITTED WITHOUT THE WRITTEN CONSENT OF HUBBELL POWER SYSTEMS. UNPUBLISHED WORKS PROTECTED UNDER THE COPYRIGHT LAWS.</small>	HUBBELL POWER SYSTEMS POWER SYSTEMS, INC.	TITLE LIGHTING FOUNDATION	SIZE SB SA112-0296	DWG NO. SA112-0296	REV B
	DO NOT SCALE THIS DRAWING	DATE 11/5/04	DRN BY KSH	SHEET 1/1	