

NO HARDWARE INCLUDED,
T112-0393 HARDWARE PACKAGE
SOLD SEPARATELY

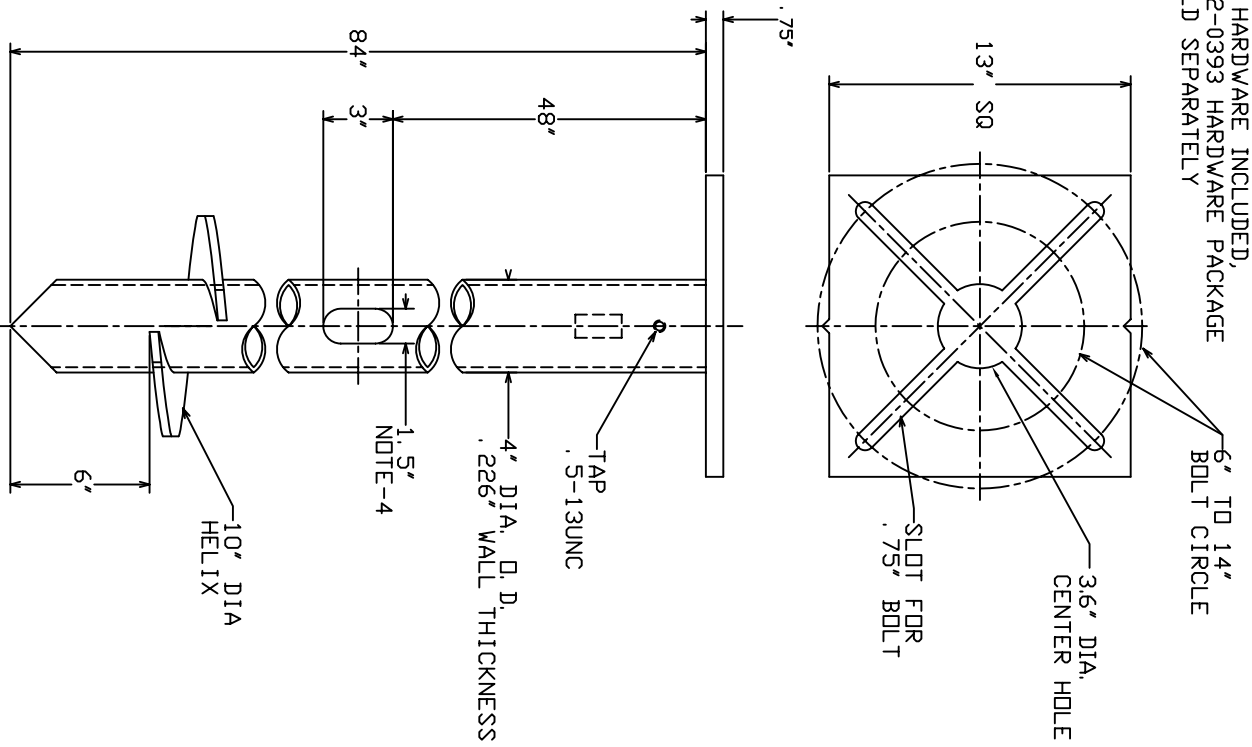

1. FINISH: HOT DIP GALVANIZE PER ASTM-A153 (LATEST REVISION).
2. BASEPLATE TO BE PERPENDICULAR TO SHAFT AXIS ($\pm 1^\circ$) AND HOLE CENTERLINE CONCENTRIC ($\pm .188$) TO SHAFT AXIS.
3. STENCIL MIN. 1/2 IN. LETTERS MANUFACTURER'S NUMBER AFTER GALVANIZING.
4. FLAME CUT TWO SLOTS IN SHAFT PERPENDICULAR TO THE BASEPLATE. PREHEAT, TUMBLEBLAST, HANDGRIND, AND CLEAN BASEPLATE, HELIX, AND PILOT POINT ON ALL WELDED AREAS.
5. FLAMECUT IRREGULARITIES PERMISSIBLE: (1) VALLEYS NOT TO EXCEED 3/32 IN. BELOW NOMINAL SURFACE LEVEL, (2) PEAKS OR POSITIVE LEVEL DR INTERSECTIONS OF NOMINAL SURFACES.
6. MANUFACTURER TO HAVE IN EFFECT INDUSTRY RECOGNIZED WRITTEN QUALITY CONTROL FOR ALL MATERIALS AND MANUFACTURING PROCESSES. ALL MATERIAL IS TO BE NEW, UNUSED AND MILL TRACEABLE MEETING THE FOLLOWING SPECIFICATIONS:

7. BASEPLATE: ASTM A36-(LATEST REVISION) HOT ROLLED STEEL PLATE
8. SHAFT: STEEL TUBING PER ASTM 500 GRADE B.
9. HELIX: ASTM A635 (LATEST REVISION) HOT ROLLED STEEL.
10. BASEPLATE IS PERMANENTLY STAMPED WITH MANUFACTURER'S IDENTIFICATION "ABC" IN 1/2" LETTERS AND THE JULIAN DATE CODE IN 1/4" LETTERS. BASEPLATE PERMANENTLY MARKED TO INDICATE CABLEWAY OPENING IN SHAFT.

T112-0393 HARDWARE PACKAGE INCLUDES:
 (4) 3/4"X3-1/2" SAE J429 GR.5 GALV. CARRIAGE BOLTS
 (4) ROUND FLAT WASHERS
 (4) 3/4" NUTS

-NOTES-

LIGHTING FOUNDATION
 CAT. NO. T112-0693

CHANCE		HUBBELL POWER SYSTEMS	
<small>CONFIDENTIAL - THIS DRAWING AND ITS CONTENTS ARE CONFIDENTIAL AND THE EXCLUSIVE PROPERTY OF HUBBELL POWER SYSTEMS. NO PART OF THIS DRAWING OR COPIES MAY BE MADE WITHOUT THE WRITTEN CONSENT OF HUBBELL POWER SYSTEMS. UNPUBLISHED. ALL RIGHTS RESERVED UNDER THE COPYRIGHT LAWS.</small>		<small>DO NOT SCALE THIS DRAWING</small>	
SIZE	DWG NO.	DWN BY	DATE
SBI	SA112-0693	KSH	11/22/04
REV	TITLE		SHEET
A	LIGHTING FOUNDATION		1/1