

- \* \* NOTES \* \*
1. MAT'L:  
 TOOL BODY - CAST STEEL  
 COIL LOCK - SPRING STEEL  
 BENT ARM PIN - COLD DRAWN STEEL
  2. FINISH:  
 TOOL BODY - PAINTED SPRUCE GREEN  
 COIL LOCK - ZINC PLATED WITH YELLOW COATING  
 BENT ARM PIN - ZINC PLATED

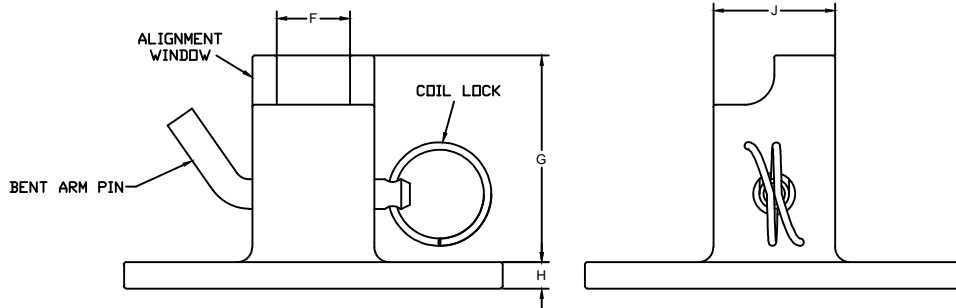
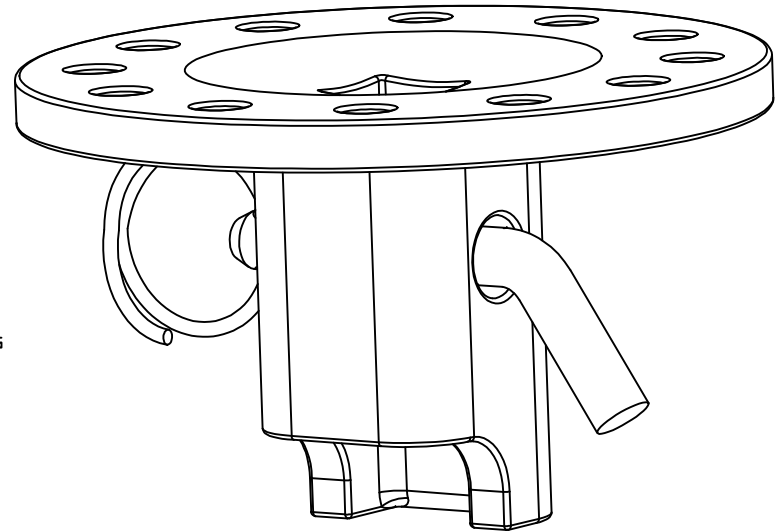

ANCHOR WRENCH	DIMENSION								
	A	B	C	D	E	F	G	H	J
SS125	6.3	5.26	0.53	6	125	1.3	3.8	0.67	2.6
SS5/SS150	6.3	5.26	0.53	6	150	1.6	4.5	0.67	2.6
SS175	9.6	7.63	0.69	12	175	1.9	5.3	0.67	3.1
SS200	9.6	7.63	0.69	12	200	2.1	6.0	0.79	3.6
SS225	9.6	7.63	0.69	12	225	2.4	6.6	0.79	4.0

CATALOG NUMBER	FAMILY	INCLUDES
C3031502*	SS125	SS125 ANCHOR WRENCH, COIL LOCK & BENT ARM PIN
C3031223	SS125	BENT ARM PIN & COIL LOCK
639001	SS5/SS150	SS5/SS150 ANCHOR WRENCH, COIL LOCK & BENT ARM PIN
C3031226	SS5/SS150	BENT ARM PIN & COIL LOCK
C3030195	SS175	SS175 ANCHOR WRENCH, COIL LOCK & BENT ARM PIN
C3031225	SS175	BENT ARM PIN & COIL LOCK
C3030201	SS200	SS200 ANCHOR WRENCH, COIL LOCK & BENT ARM PIN
C3031224	SS200	BENT ARM PIN & COIL LOCK
C3030202	SS225	SS225 ANCHOR WRENCH, COIL LOCK & BENT ARM PIN
C3031224	SS225	BENT ARM PIN & COIL LOCK
P0010259P	SS125-SS150	1/2" GRADE 5 BOLT (QTY 1)
055635P	SS125-SS150	1/2" GRADE 5 HEX NUT (QTY 1)
055371P	SS125-SS150	1/2" SPRING LOCKWASHER (QTY 1)
056154P	SS175-SS225	5/8" GRADE 2 BOLT (QTY 1)
055803P	SS175-SS225	5/8" GRADE 2 HEX NUT (QTY 1)
058827P	SS175-SS225	5/8" SPRING LOCKWASHER (QTY 1)

\* DOES NOT INCLUDE ALIGNMENT WINDOW

<b>CHANCE</b> TOLERANCE CHART		<b>HUBBELL® POWER SYSTEMS</b> ANCHOR WRENCH	
<small>CONFIDENTIAL: THIS DRAWING AND ITS CONTENTS ARE CONFIDENTIAL AND THE EXCLUSIVE PROPERTY OF HUBBELL POWER SYSTEMS. NO PUBLICATION, DISTRIBUTION OR COPIES MAY BE MADE WITHOUT THE WRITTEN CONSENT OF HUBBELL POWER SYSTEMS. HUBBELL POWER SYSTEMS UNPUBLISHED. ALL RIGHTS RESERVED UNDER THE COPYRIGHT LAWS.</small>			
SIZE: B DO NOT SCALE THIS DRAWING	DRW NO.: SA3031502	CAT / PART / ASSY NO.: SEE CHART	REV: A
DRN BY: TMK	DATE: 11/6/12	SHEET: 1/1	