

ROCK-IT™

HELICAL LEAD SECTION

SS150

TORQUE STRENGTH RATING: 7,000 FT-LB
 ULTIMATE CAPACITY* (TENSION/COMPRESSION): 70,000 LB
 *BASED ON A TORQUE FACTOR ($K_t=10$)
 ULTIMATE TENSION STRENGTH (COUPLING BOLT): 70,000 LB

PART NUMBER	DESCRIPTION	'A'	'B'	'C'	'D'	'E'	'F'
C1501488	LEAD, SS150, 6/8 X 3FT, ROCK-IT™	36.6	31.0	6	8	-	1.50
C1501489	LEAD, SS150, 8/10 X 3FT, ROCK-IT™	36.6	31.0	8	10	-	1.50
C1501505	LEAD, SS150, 8/10 X 5FT, ROCK-IT™	64.3	59.0	8	10	-	1.50

SS175

TORQUE STRENGTH RATING: 10,500 FT-LB
 ULTIMATE CAPACITY* (TENSION/COMPRESSION): 105,000 LB
 *BASED ON A TORQUE FACTOR ($K_t=10$)
 ULTIMATE TENSION STRENGTH (COUPLING BOLT): 105,000 LB

PART NUMBER	DESCRIPTION	'A'	'B'	'C'	'D'	'E'	'F'
C1501507	LEAD, SS175, 8/10 X 5FT, ROCK-IT™	64.3	59.0	8	10	-	1.75
C1501509	LEAD, SS175, 8/10/12 X 5FT, ROCK-IT™	64.3	59.0	8	10	12	1.75
C1501511	LEAD, SS175, 6/8 X 3FT, ROCK-IT™	36.6	31.0	6	8	-	1.75
C1501513	LEAD, SS175, 8/10 X 3FT, ROCK-IT™	36.6	31.0	8	10	-	1.75

SS200

TORQUE STRENGTH RATING: 16,000 FT-LB
 ULTIMATE CAPACITY* (TENSION/COMPRESSION): 150,000 LB
 *BASED ON A TORQUE FACTOR ($K_t=10$)
 ULTIMATE TENSION STRENGTH (COUPLING BOLT): 150,000 LB

PART NUMBER	DESCRIPTION	'A'	'B'	'C'	'D'	'E'	'F'
C1501532	LEAD, SS200, 8/10/12 X 7FT, ROCK-IT™	85.3	81.3	8	10	12	2.00
C1501612	LEAD, SS200, 6/8/10 X 5FT, ROCK-IT™	65.6	60.5	6	8	10	2.00

SS225

TORQUE STRENGTH RATING: 21,000 FT-LB
 ULTIMATE CAPACITY* (TENSION/COMPRESSION): 200,000 LB
 *BASED ON A TORQUE FACTOR ($K_t=10$)
 ULTIMATE TENSION STRENGTH (COUPLING BOLT): 200,000 LB

PART NUMBER	DESCRIPTION	'A'	'B'	'C'	'D'	'E'	'F'
C1501544	LEAD, SS225, 8/10/12 X 7FT, ROCK-IT™	78.7	74.7	8	10	12	2.25

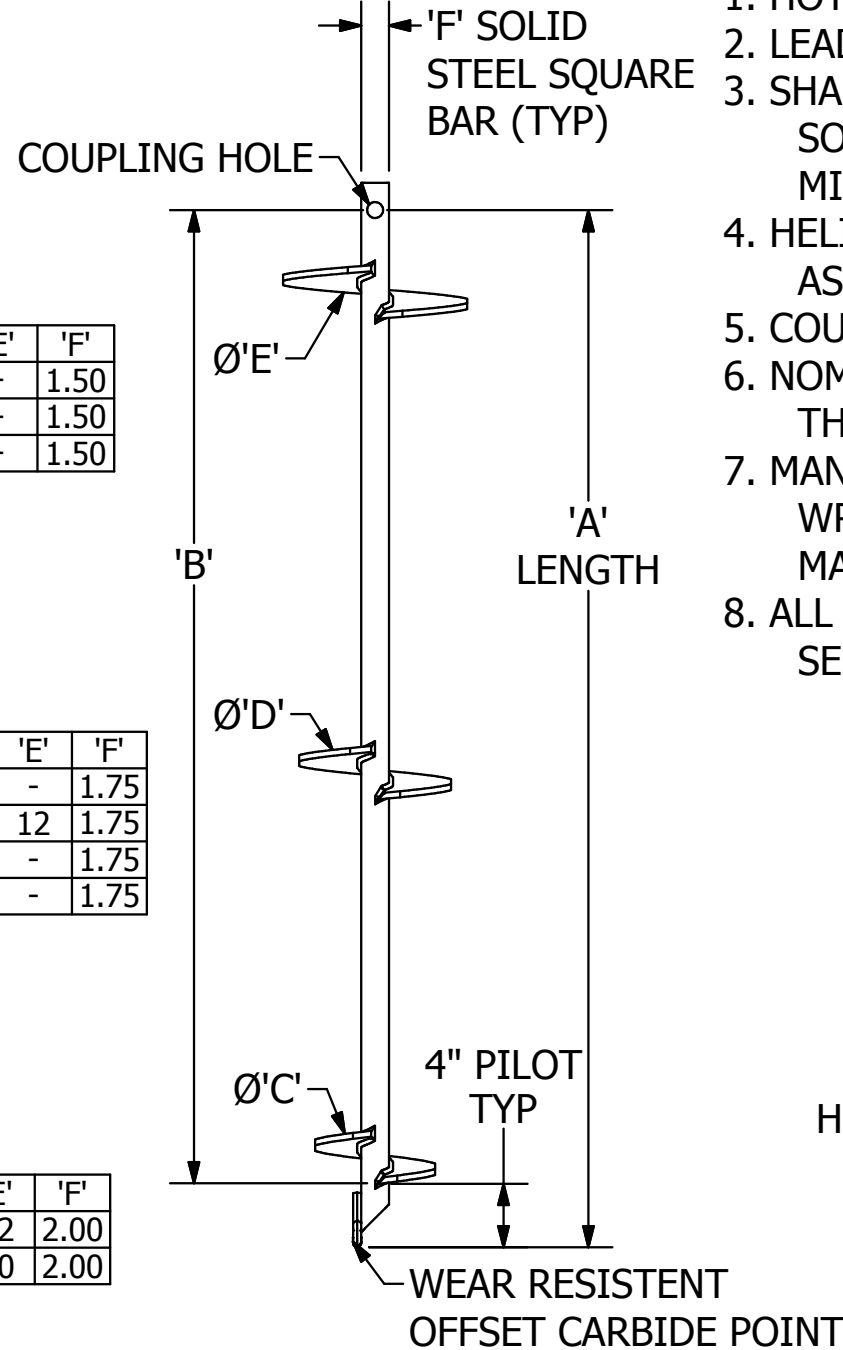

LEAD SECTION

* * NOTES * *

1. HOT DIP GALVANIZED PER ASTM A153 (LATEST REV).
2. LEAD SECTION LENGTHS AND HELIX SPACINGS ARE NOMINAL.
3. SHAFT MATERIAL: HOT HOLLOWED ROUND-CORNER-SQUARE(RCS) SOLID STEEL BARS PER ASTM A29; MINIMUM YIELD STRENGTH: 120 KSI.
4. HELIX MATERIAL: HOT ROLLED CARBON STEEL PER ASTM A656, GRADE 80.
5. COUPLING BOLTS PER ASTM A325 TYPE 1.
6. NOMINAL SPACING BETWEEN HELIX PLATES IS THREE TIMES THE DIAMETER OF THE LOWER HELIX.
7. MANUFACTURER TO HAVE IN EFFECT INDUSTRY RECOGNIZED WRITTEN QUALITY CONTROL FOR ALL MATERIALS AND MANUFACTURING PROCESSES.
8. ALL WELDING TO BE DONE BY WELDERS CERTIFIED UNDER SECTION 5 OF THE AWS CODE D1.1.

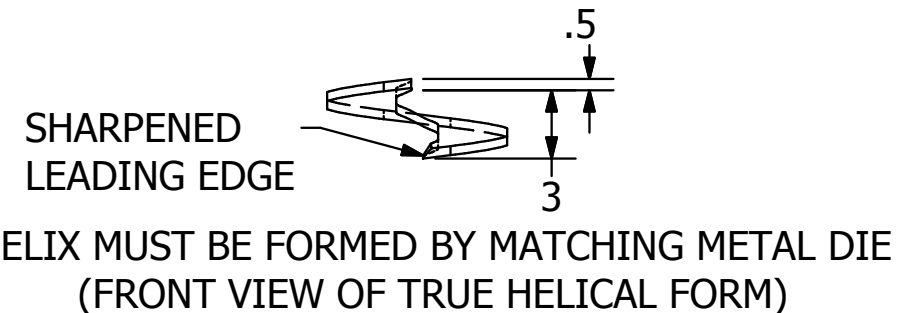

CHANCE ®	HUBBELL ® POWER SYSTEMS, INC.		HUBBELL POWER SYSTEMS, INC.	
	TITLE ROCK-IT™			
CONFIDENTIAL: THIS DRAWING AND ITS CONTENTS ARE CONFIDENTIAL AND THE EXCLUSIVE PROPERTY OF HUBBELL POWER SYSTEMS. NO PUBLICATION, DISTRIBUTION, OR COPIES MAY BE MADE WITHOUT THE WRITTEN CONSENT OF HUBBELL POWER SYSTEMS. HUBBELL POWER SYSTEMS UNPUBLISHED ALL RIGHTS RESERVED UNDER THE COPYRIGHT LAWS.	SIZE B	CAT / PART / ASSY NO. SEE CHART	DWG NO. SA1501488	REV F
	DO NOT SCALE THIS DRAWING	DRN BY TMK	DATE 11/10/15	SHEET 1 OF 1