

RECOMMENDED TORQUE
NO GREATER THAN
15,000 FT. LB.

NO HARDWARE INCLUDED, T112-0632
HARDWARE PACKAGE SOLD SEPARATELY

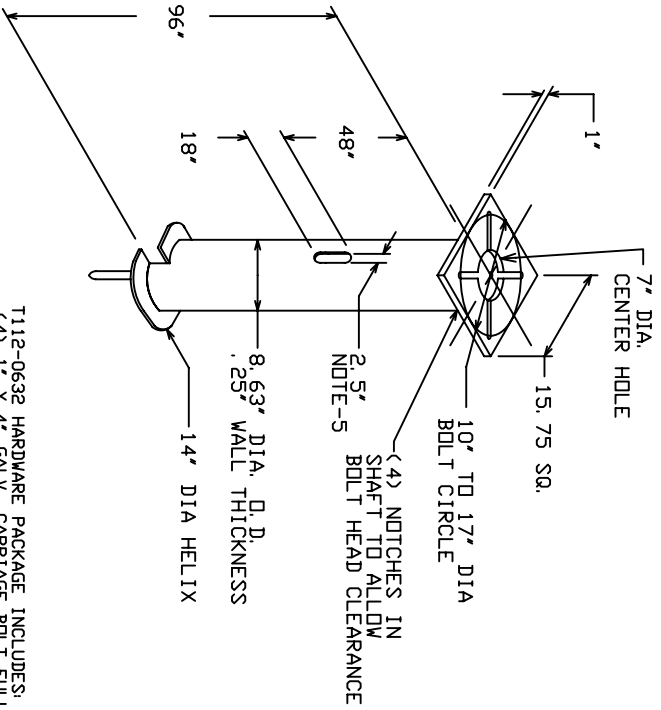

T112-0632 HARDWARE PACKAGE INCLUDES:
(4) 1" X 4" GALV. CARRIAGE BOLT FULL THREADS
(4) ROUND FLAT WASHERS,
(5) LOCK NUTS,
(4) LOCK WASHERS
(4) 3" X 3" X 1/4" TAPPED RETAINING WASHER

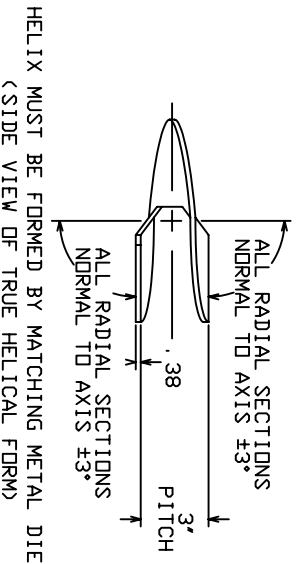

HELIX MUST BE FORMED BY MATCHING METAL DIE
<SIDE VIEW OF TRUE HELICAL FORM>

LIGHTING FOUNDATION
CAT. NO. T112-0629

-NOTES-

1. FINISH: HOT DIP GALVANIZE PER ASTM-A153 (LATEST REVISION).
2. BASEPLATE TO BE PERPENDICULAR TO SHAFT AXIS (±1°) AND HOLE CENTERLINE CONCENTRIC (±.188) TO SHAFT AXIS.
3. STENCIL MIN. 1/2 IN. LETTERS MANUFACTURER'S NUMBER AFTER GALVANIZING.
4. PILOT POINT AND SHAFT AXES TO BE CONCENTRIC (±.125 FIM) AND IN LINE (±2°).
5. FLAME CUT SLOT PERPENDICULAR TO THE BASEPLATE.
6. PREHEAT, TUMBLEBLAST, HANDGRIND, AND CLEAN BASEPLATE, HELIX, AND PILOT POINT ON ALL WELDED AREAS.
7. FLAMECUT IRREGULARITIES PERMISSIBLE: (1) VALLEYS NOT TO EXCEED 3/32 IN. BELOW NOMINAL SURFACE LEVEL, (2) PEAKS OR POSITIVE IRREGULARITIES NOT TO EXCEED 1/32 IN. ABOVE NOMINAL SURFACE LEVEL OR INTERSECTIONS OF NOMINAL SURFACES.
8. MANUFACTURER TO HAVE IN EFFECT INDUSTRY RECOGNIZED WRITTEN QUALITY CONTROL FOR ALL MATERIALS AND MANUFACTURING PROCESSES. ALL MATERIAL IS TO BE NEW, UNUSED AND MILL TRACEABLE MEETING THE FOLLOWING SPECIFICATIONS:
- 9.

BASEPLATE: ASTM A36-(LATEST REVISION) STRUCTURAL STEEL
(CONFORM TO AASHTO TECH. BUL. #270).

SHAFT: ASTM A252-(LATEST REVISION) GRADE 2, STEEL PIPE PILES.
ALTERNATE MATERIAL: ASTM A53-(LATEST REVISION) TYPE E OR S, GRADE B, STEEL PIPE OR ASTM A500-(LATEST REVISION) GRADE B, STRUCTURAL STEEL TUBING.

HELIX: ASTM A635-(LATEST REVISION) 3/8" THICK HOT ROLLED STEEL
PLATE OR COIL.

PILOT POINT: ASTM A575-(LATEST REVISION) 1-1/4" DIAMETER HOT ROLLED
STEEL BAR

BOLTS: CARRIAGE BOLT PER ANSI B-18.5, SAE J429 GRADE-5.

10. BASEPLATE IS PERMANENTLY STAMPED WITH MANUFACTURER'S IDENTIFICATION 'ABC' IN 1/2" LETTERS AND DATE CODE IN 1/4" LETTERS.
11. BASEPLATE PERMANENTLY MARKED TO INDICATE CABLEWAY OPENING IN SHAFT.

| | | | |
|---|------------|-----------------------|-----------|
| CHANCE | | HUBBELL POWER SYSTEMS | |
| CONFIDENTIAL: THIS DRAWING AND ITS CONTENTS ARE THE PROPERTY OF HUBBELL POWER SYSTEMS. NO PUBLICATION, DISTRIBUTION OR COPIES MAY BE MADE WITHOUT THE WRITTEN CONSENT OF HUBBELL POWER SYSTEMS UNPUBLISHED. ALL RIGHTS RESERVED UNDER THE COPYRIGHT LAWS. | | HUBBELL POWER SYSTEMS | |
| SIZE | DWG NO. | DATE | REV. |
| SB | SA112-0629 | 11/9/04 | B |
| DO NOT SCALE THIS DRAWING | DWN BY KSH | DATE | SHEET 1/1 |