

-NOTES-

1. FINISH: HOT DIP GALVANIZE PER ASTM-A153 (LATEST REVISION).
2. BASEPLATE TO BE PERPENDICULAR TO SHAFT AXIS ( $\pm 1^\circ$ ) AND HOLE CENTERLINE CONCENTRIC ( $\pm .188$ ) TO SHAFT AXIS.
3. STENCIL MIN. 1/2 IN. LETTERS MANUFACTURER'S NUMBER AFTER GALVANIZING.
4. PILOT POINT AND SHAFT AXES TO BE CONCENTRIC ( $\pm .125$  FIM) AND IN LINE ( $\pm 2^\circ$ ).
5. FLAME CUT TWO SLOTS IN SHAFT PERPENDICULAR TO THE BASEPLATE. PREHEAT, TUMBLEBLAST, HANDGRIND, AND CLEAN BASEPLATE, HELIX, AND PILOT POINT ON ALL WELDED AREAS.
6. FLAMECUT IRREGULARITIES PERMISSIBLE: (1) VALLEYS NOT TO EXCEED 3/32 IN. BELOW NOMINAL SURFACE LEVEL, (2) PEAKS OR POSITIVE IRREGULARITIES NOT TO EXCEED 1/32 IN. ABOVE NOMINAL SURFACE LEVEL OR INTERSECTIONS OF NOMINAL SURFACES.
8. MANUFACTURER TO HAVE IN EFFECT INDUSTRY RECOGNIZED WRITTEN QUALITY CONTROL FOR ALL MATERIALS AND MANUFACTURING PROCESSES. ALL MATERIAL IS TO BE NEW, UNUSED AND MILL TRACEABLE MEETING THE FOLLOWING SPECIFICATIONS:

BASEPLATE: ASTM A36-(LATEST REVISION) STRUCTURAL STEEL  
(CONFORM TO AASHTO TECH. BUL. #270).

SHAFT: ASTM A252-(LATEST REVISION) GRADE 2, STEEL PIPE PILES.  
ALTERNATE MATERIAL: ASTM A53-(LATEST REVISION) TYPE E DR S, GRADE B, STEEL PIPE OR ASTM A500-(LATEST REVISION) GRADE B, STRUCTURAL STEEL TUBING.

HELIX: ASTM A635-(LATEST REVISION) 3/8" THICK HOT ROLLED STEEL  
PLATE OR COIL.

PILOT POINT: ASTM A575-(LATEST REVISION) 1-1/4" DIAMETER HOT ROLLED  
STEEL BAR.

BOLTS: 3/4"-10 UNC X 2-1/2" HEX BOLT SAE J429 GRADE 5  
OR ASTM A193 GRADE B7.

10. BASEPLATE IS PERMANENTLY STAMPED WITH MANUFACTURER'S IDENTIFICATION 'ABC' IN 1/2" LETTERS AND DATE CODE
11. BASEPLATE PERMANENTLY MARKED TO INDICATE CABLEWAY OPENING IN SHAFT.

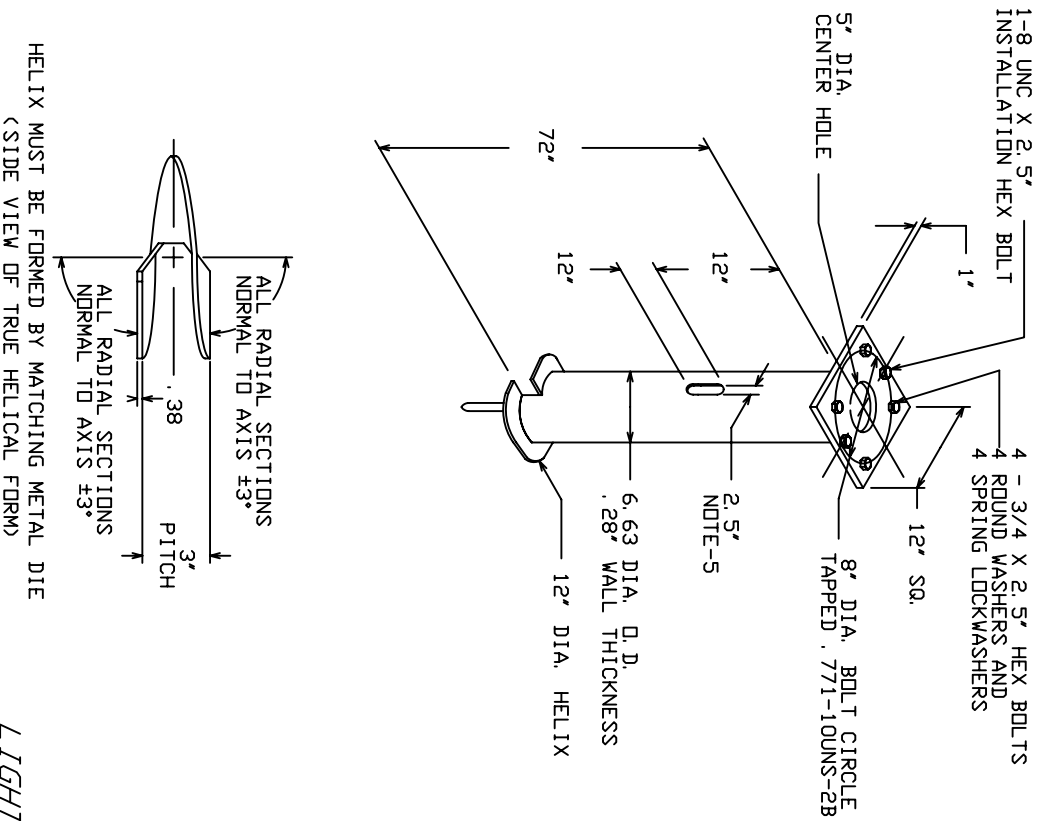

HELIX MUST BE FORMED BY MATCHING METAL DIE  
(SIDE VIEW OF TRUE HELICAL FORM)

*LIGHTING FOUNDATION  
CAT. NO. 1112-0648*

|                           |              |                       |               |
|---------------------------|--------------|-----------------------|---------------|
| <b>CHANCE</b>             |              |                       |               |
| TITLE                     |              | HUBBELL POWER SYSTEMS |               |
| SB                        |              | LIGHTING FOUNDATION   |               |
| DO NOT SCALE THIS DRAWING | SIZE DWG NO. | DNB BY KSH            | DATE 10/29/04 |
|                           | SA112-0648   |                       |               |
|                           |              |                       | SHEET 1/1     |
|                           |              |                       | REV A         |